

## **FS3 SERIES LENSES**

**for SEOUL SEMICONDUCTOR Z-POWER P3™ LEDs**

- **High efficiency**
- **Available in 3 different beams**
- **50mm diameter sized for MR16 lamp applications**
- **Patent Pending**

The FS3 series Low Profile Tri-lens module is available for the Seoul Semiconductor LEDs : Z-Power P3™. [www.seoulsemiconductor.com](http://www.seoulsemiconductor.com)

A software-optimized aspheric profile combined with front shaped micro-lens arrays enable the generation of three different lens models: narrow, medium and wide beam.

The high collection efficiency reaches 85% of the total flux emitted from the LED.

These lenses are assembled with a 50mm diameter holder. The holder assures the proper relative placement between the lens and the Z-Power P3™ LEDs. Heat staking the three legs of the holder to the customer's PCB or heat sink provides excellent optical and mechanical assembly (see Fraen Application Note FAN01-EN, at [www.fraensrl.com](http://www.fraensrl.com)).

Typical applications are:

- Reading lamps
- Internal fittings with MR16 standard
- Architectural Lighting
- Flash lights
- Most application where uniformity and high intensity over a wide angle is required.

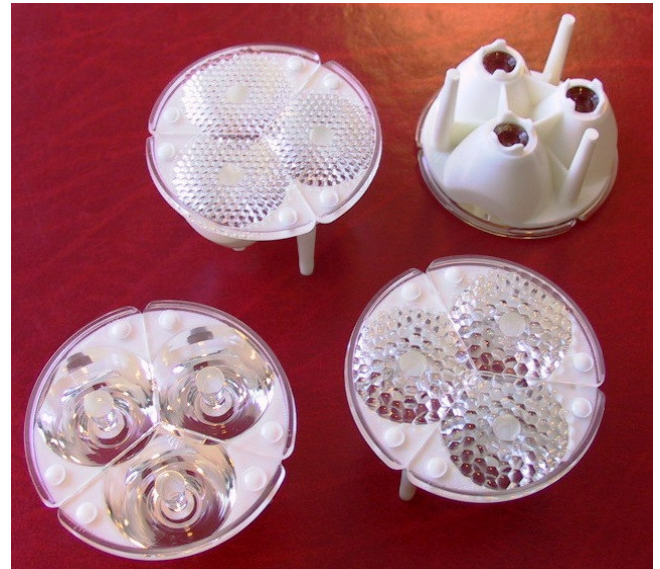

(1) Z-Power is a trademark of Seoul Semiconductor. For technical specification on LEDs please refer to the Z-Power datasheet or visit [www.seoulsemiconductor.com](http://www.seoulsemiconductor.com)

*For ordering instructions, please contact*

**FRAEN CORPORATION**

Scott M. Grzenda  
80 Newcrossing Road  
Reading MA 01867  
Phone: 781.205.5300  
Fax: 781.942.2426  
[optics@fraen.com](mailto:optics@fraen.com)

**FRAEN Srl**

Dimitri De Gaetano  
Via E. Fermi, 7  
20090 Settimo M (MI) – Italy  
Phone: +39-02-335.456.225  
Fax: +39 02-335.456.239  
[info@fraen.com](mailto:info@fraen.com)

*To find a local distributor, check the Fraen website.*

Website: [www.fraensrl.com](http://www.fraensrl.com)



## General Characteristics

---

Lens Material	Optical Grade PMMA
Holder Material	PC ABS
Operating Temperature range	-40deg C / + 80 deg C
Storage Temperature range	-40deg C / + 80 deg C

Average transmittance in visible spectrum (400 – 700nm) >90%, as measured using 3mm thick Optical Grade PMMA.

*Please note that flow lines and weld lines on the external surfaces of the lenses are acceptable if the optical performance of the lens is within the specification described in the section "OPTICAL CHARACTERISTICS"*

### **IMPORTANT NOTE – Lenses handling and cleaning:**

*Handling: Always use gloves to handle lenses and/or handle the lenses only by the flange. Never touch the outside surfaces of the lenses with fingers; finger oils and contamination will absorb or refract light.*

*Cleaning: Clean lenses only if necessary. Use only soap and water to clean the surfaces and lenses. Never expose the lenses to alcohol, as it will damage the plastic.*



## Optical Characteristics:

		Typical total divergence* (degrees)			
Lens Part Number	Type of lens	Blue LEDs ●	Green LEDs ●	Red LEDs ●	White LEDs ○
FS3-HNB1-SSP3-H	Narrow beam	10.0	10.0	9.5	13.0
FS3-HMB1-SSP3-H	Medium beam	22.0	21.5	21.0	22.5
FS3-HWB1-SSP3-H	Wide beam	47.0	46.5	45.5	44.5

- The typical divergence varies with LED color due to different chip size and chip position tolerance.
- The typical total divergence is the full angle measured where the luminous intensity is half of the peak value.

		Typical on-axis efficiency* (cd/lm) (2)(3)			
Lens Part Number	Type of lens	Blue LEDs ●	Green LEDs ●	Red LEDs ●	White LEDs ○
FS3-HNB1-SSP3-H	Narrow beam	13.9	24.1	19.6	14.7
FS3-HMB1-SSP3-H	Medium beam	3.5	4.9	3.3	3.8
FS3-HWB1-SSP3-H	Wide beam	1.4	1.6	1.2	1.6

(2) To calculate the on-axis intensity, multiply the on-axis efficiency of the lens (cd/lm) by the total flux of the Z-Power LED used. For more detail on flux binning please check the Z-Power LED datasheet at <http://www.seoulsemiconductor.com/>.

(3) Luminous intensity depends on the flux binning and tolerances of the LEDs. Please refer to the Z-Power datasheet for more details on flux binning and mechanical tolerances.

(\*) Measurements are made with preliminary lenses. Values can be different with full production.

## Mechanical Characteristics

---

The FS3 series of tri-lenses has been specifically optimized for the Z-Power P3 LEDs. For best optical performance (shown above), correct mechanical position of the lens on the LEDs is critical. To achieve correct lens position on the LED, the module comes pre-assembled in a holder.

### View of the assembly lens + holder:

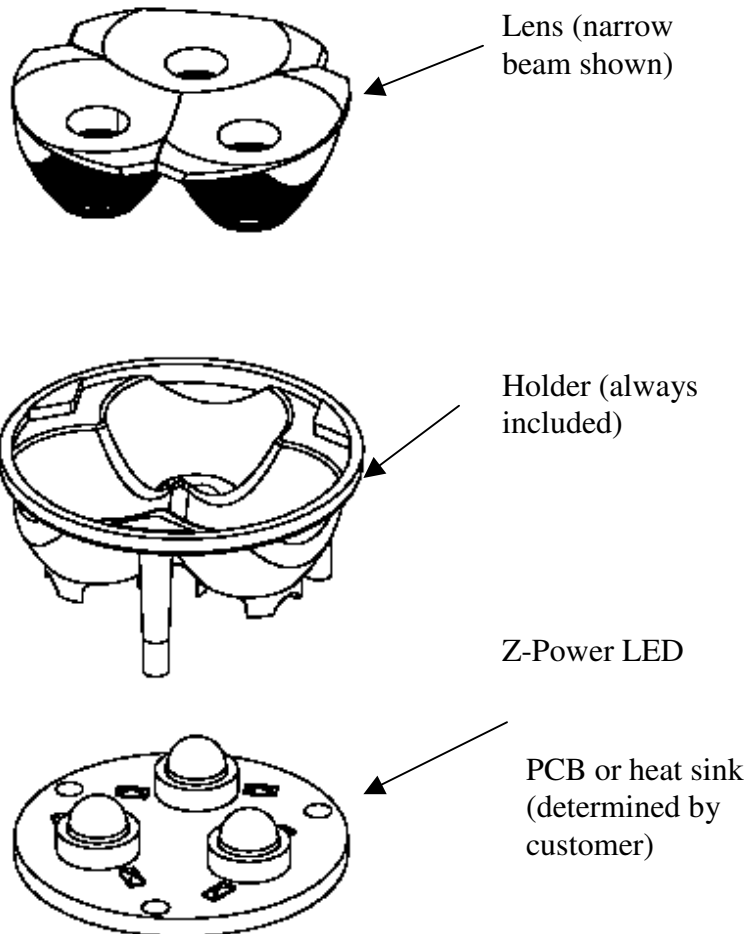

**Lens + holder assembly view and dimensions:**

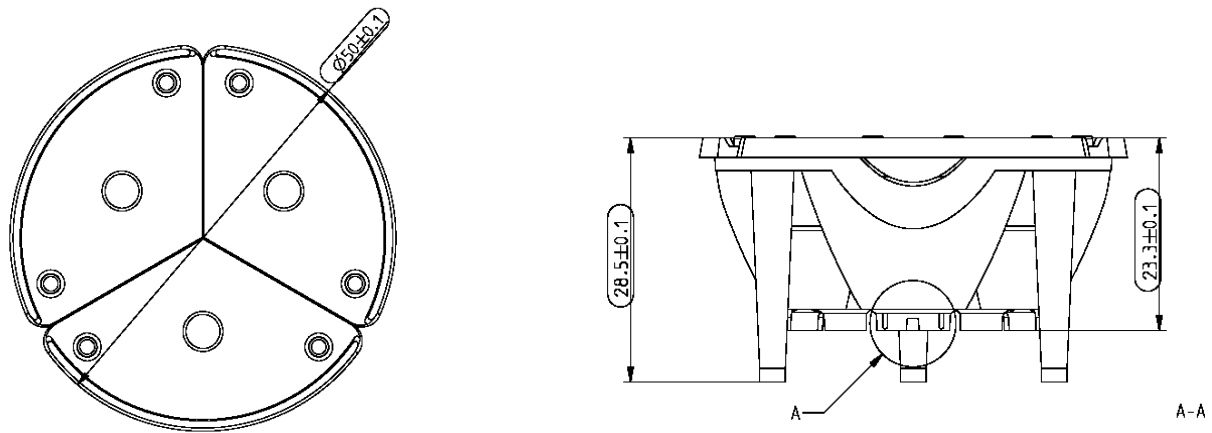

The outer geometry of all the Tri-lenses (Narrow, Medium and Wide beam) are the same except for the fronts of the lenses. The lens can be identified by the front view:

**Front Lens views:**

Narrow beam lens

Medium beam lens

Wide beam lens

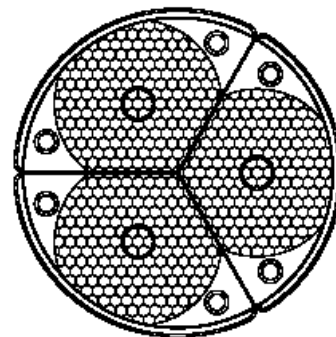
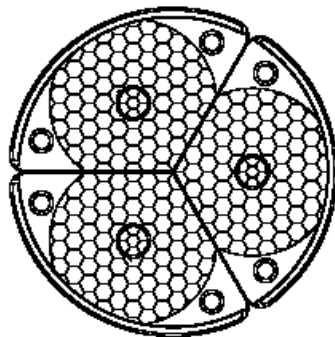
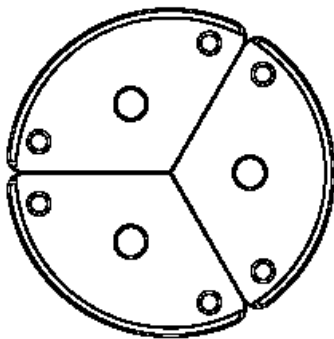



## Ordering part numbers

---

FS3-HxB1-SSP3-H



**LENS TYPE:**  
N = Narrow beam lens  
M = Medium beam lens  
W = Wide beam lens

*Published by Fraen Corporation.  
All technical data contained in this document are properties of Fraen Corporation and may change without notice.*

### Document Revision Record

Rev	Date	Author	Description
00	08-17-2006	S.A.H.	Initial Release
01	09-29-2006	S.A.H.	Corrected Part Number